

MANEJO DEL ESTRÉS DOCENTE
PARA HACER EFICIENTE
EL PROCESO PEDAGÓGICO

MIGUELINA JUSTO, M. C.

2

¡HOLA!

Miguelina Justo

miguelinajusto@gmail.com



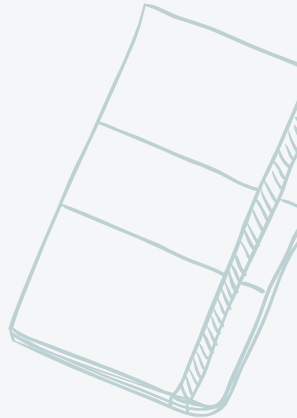

ESTRÉS



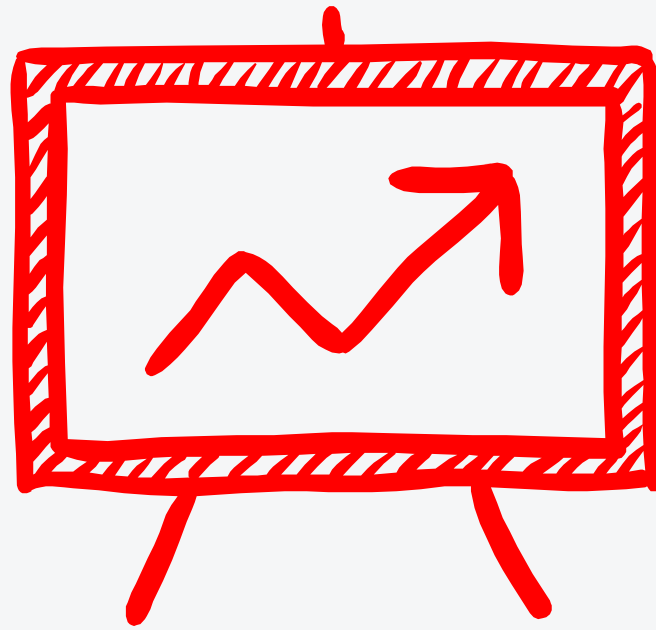

ENSEÑAR

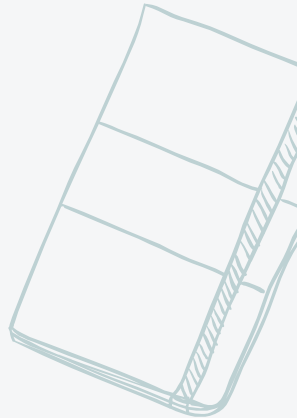



*“Lo que no se mide
no mejora”*

Carlos de Marco

TERMÓMETRO PERSONAL

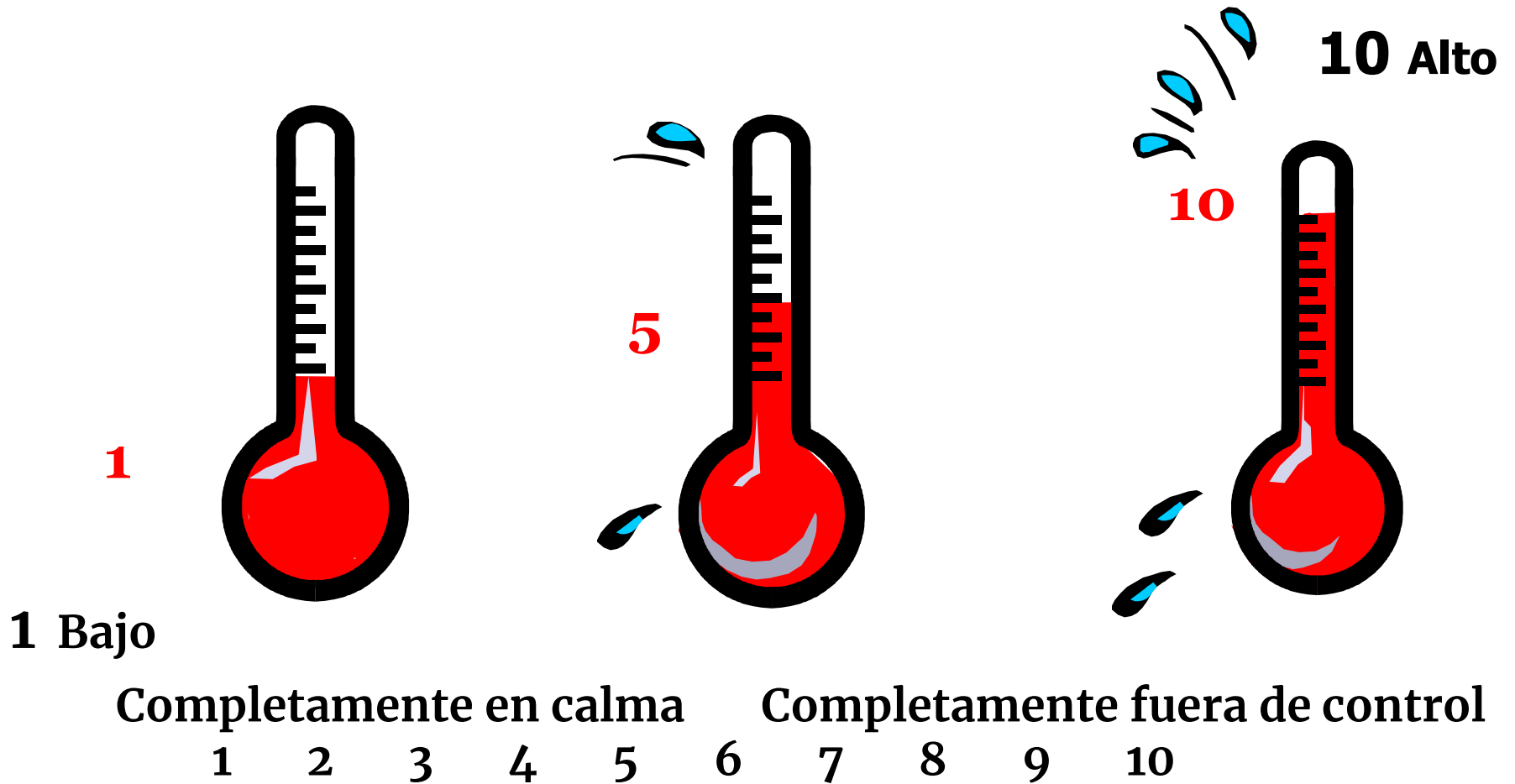

¿QUÉ SERÁ **DIFERENTE?**



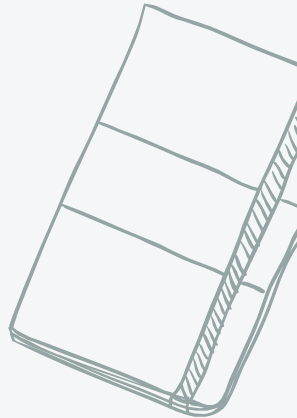
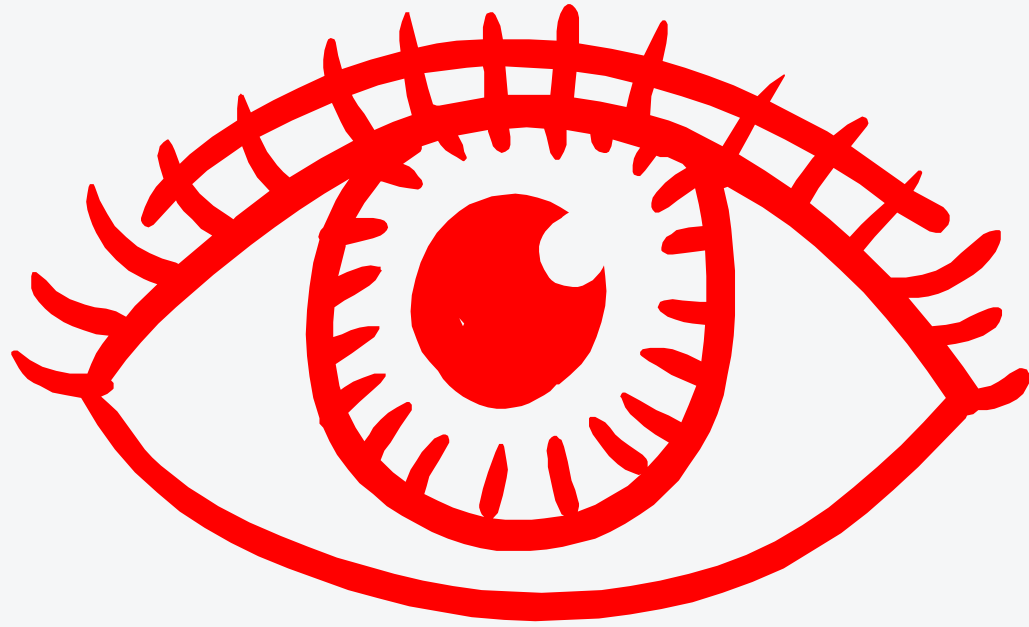





A cartoon illustration of a young boy with a worried expression, sitting at a desk and writing on a piece of paper with a blue pen. He is surrounded by several speech bubbles containing names of teachers and the word 'AUSENTE!' (Absent).

PROFESORA
CLAUDIA

PROFESOR
LUIS

PROFESORA
ELBA

AUSENTE!

AUSENTE!

AUSENTE!

*Chuan
Cavall
2007*

¿QUÉ ESPERAN DE MÍ?



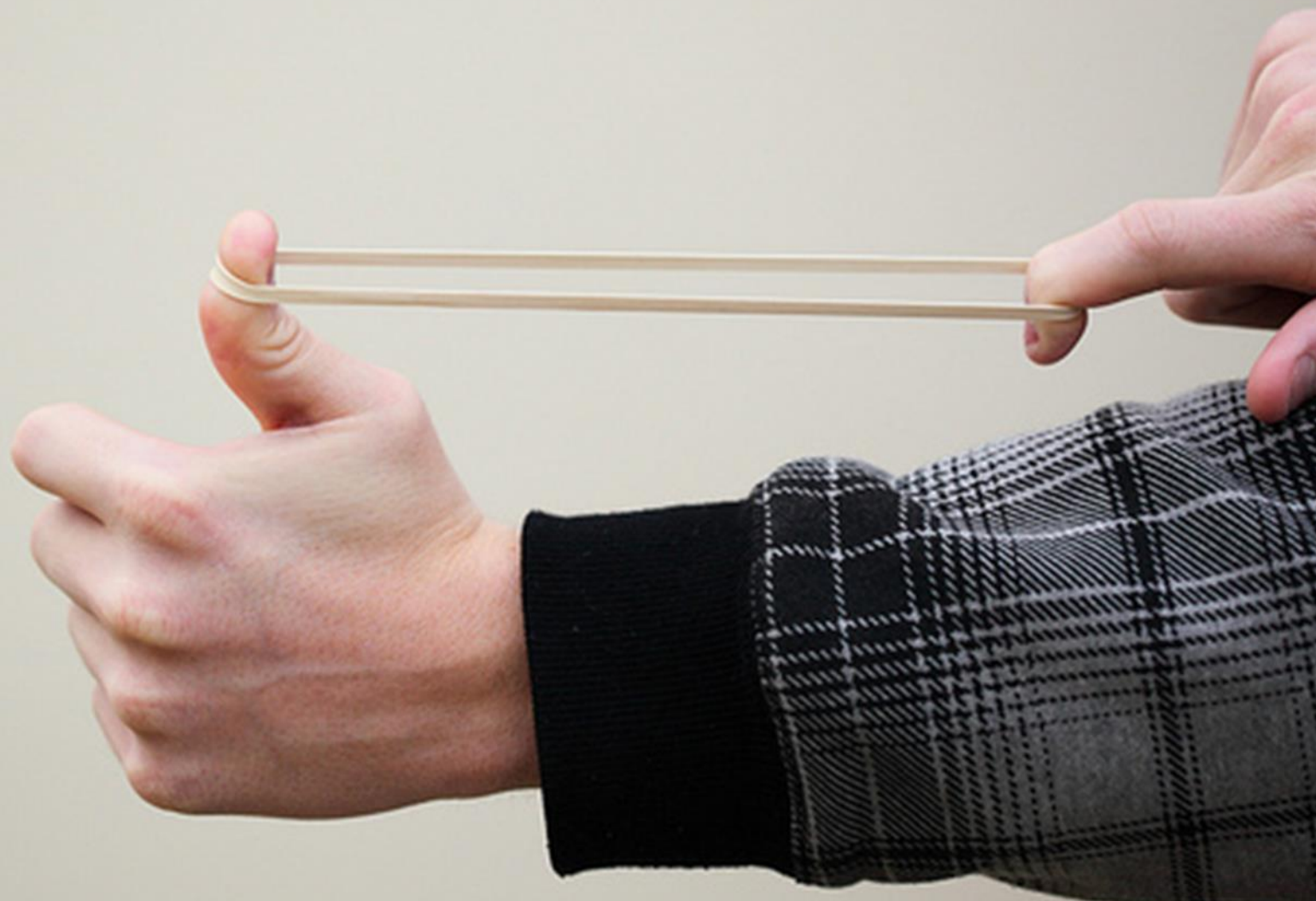



ESTRÉS

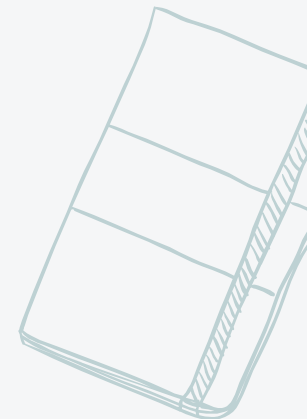



¿SOMOS ANIMALES?

¡OJALÁ ASÍ FUERA!



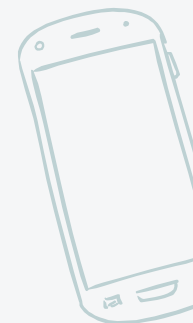
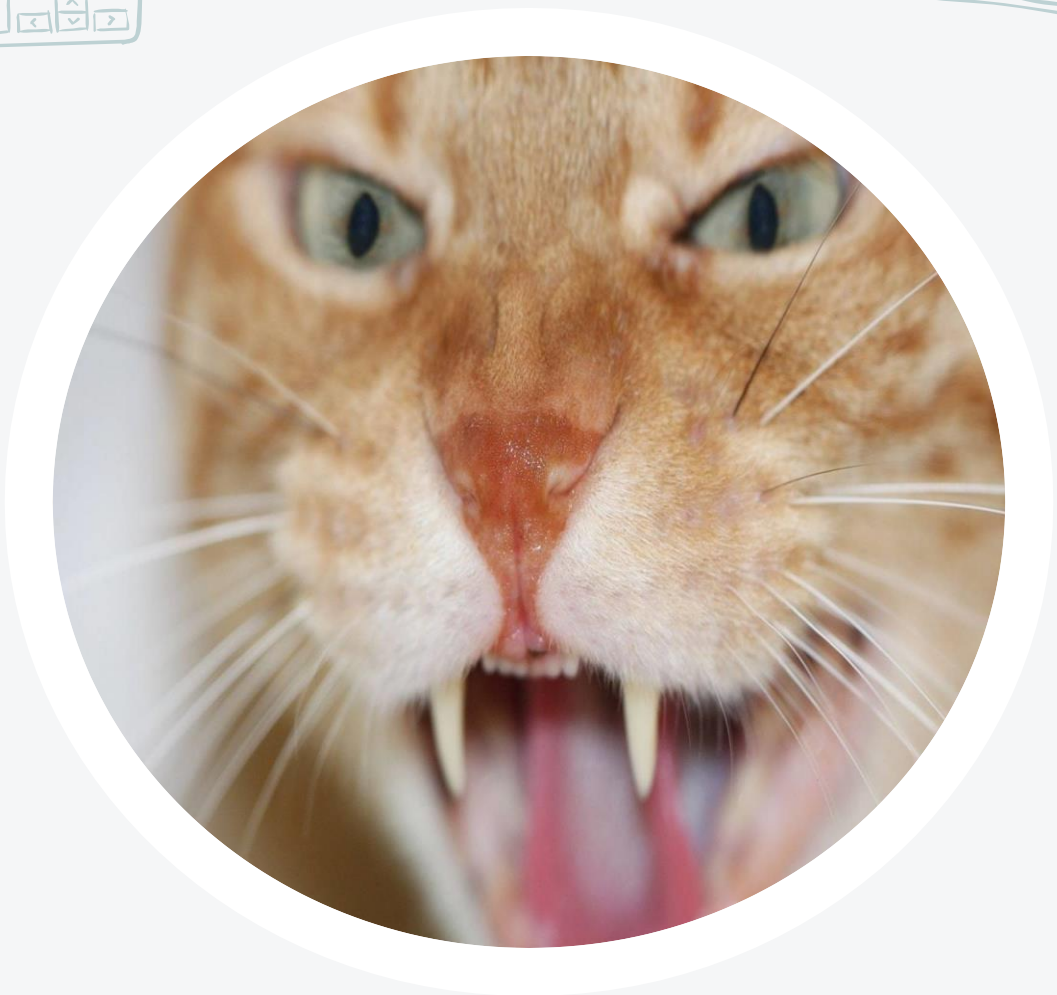

ATACO

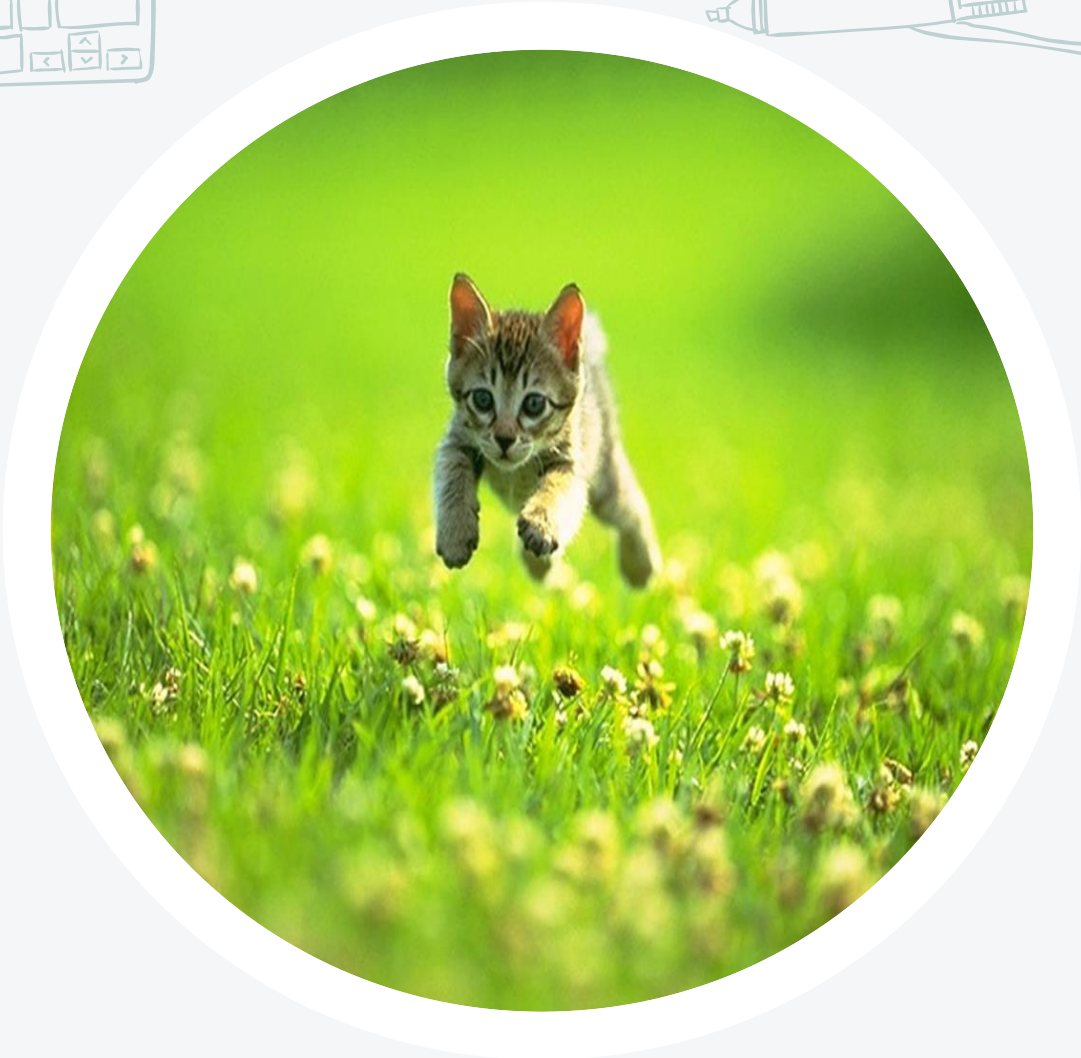

PARA QUE DIGAN QUE AQUÍ MURIÓ....



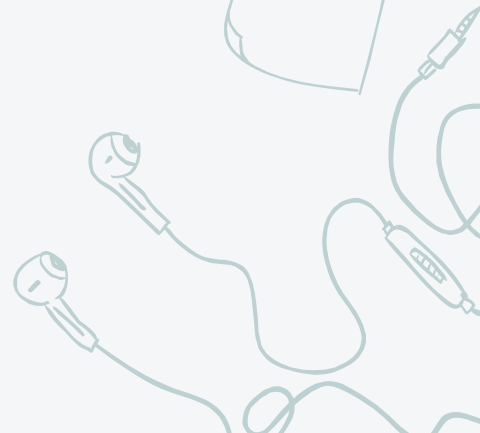
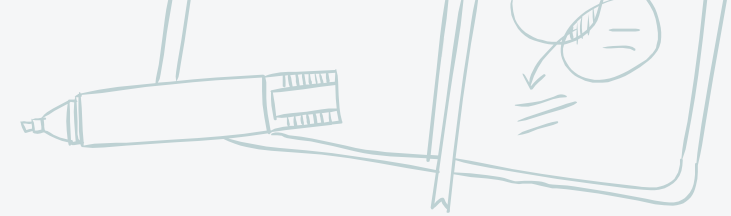

NADA HAGO...

¿QUÉ PASA CON
NOSOTROS?

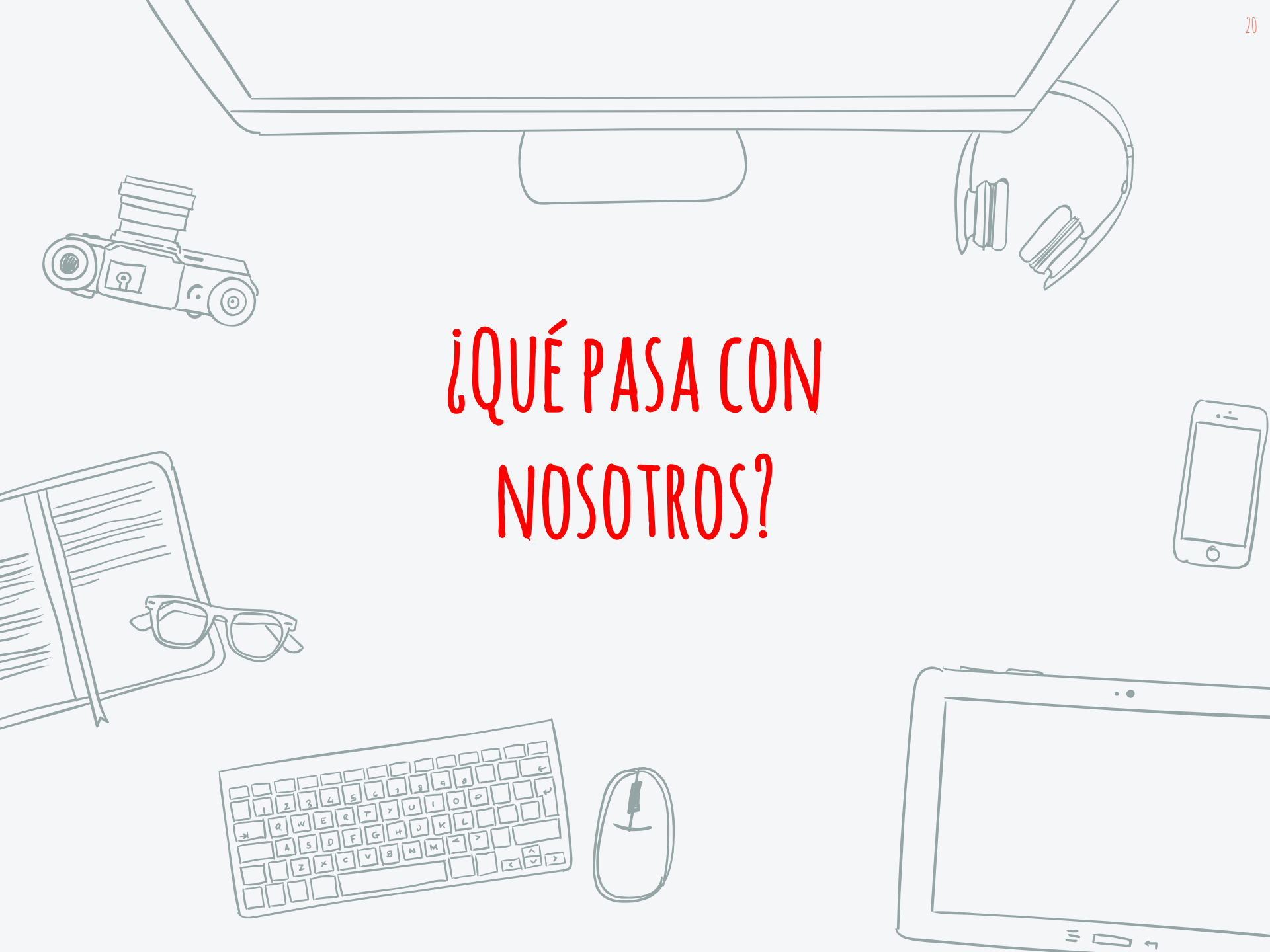



CUÁNDO SE CONVIERTE EN UN PROBLEMA

LAZARUS & FOLKMAN, 1984

Valoración
primaria



!Esto es
peligroso!

Valoración
secundaria



¡No puedo!



HABÍA UNA VEZ...



DESCUBRE LA DIFERENCIA





EN UN PAÍS MUY LEJANO...



¿QUÉ PERTURBABA AL HOMBRE?





¿CÓMO SE LIBERÓ DE LA PERTURBACIÓN?

ENTONCES, ¿CUÁLES
SON LOS **OBSTÁCULOS**?

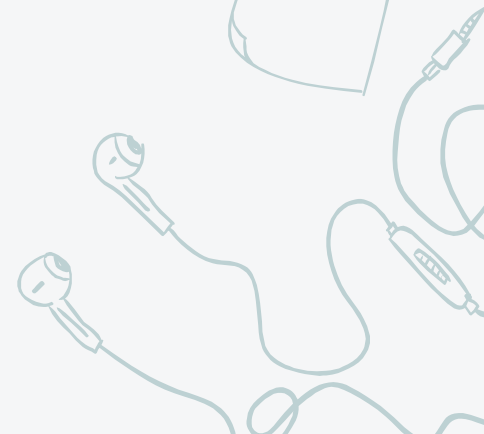
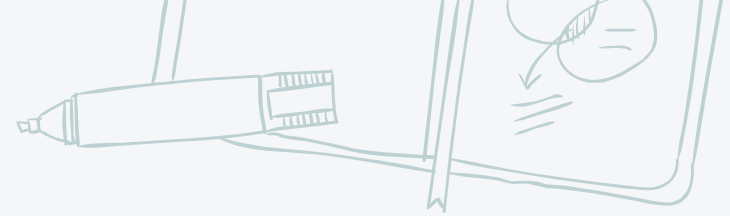

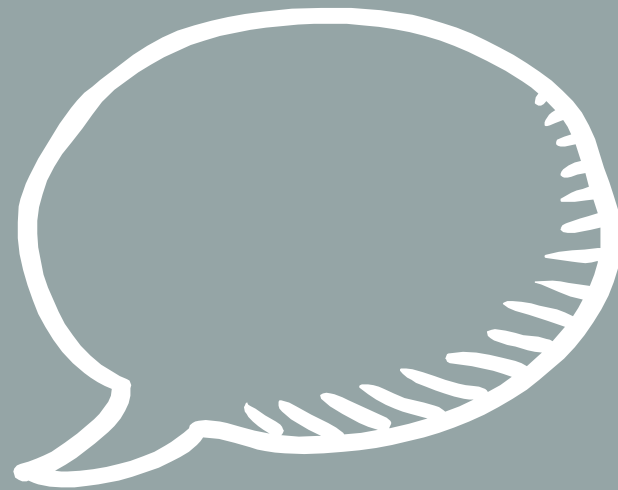

¿CUÁLES SON LAS IDEAS
QUE ME FRENAN?





Todo debo hacerlo
siempre de manera
perfecta.



Debo
complacer
a todos.



Debo estar siempre
disponible.

Mejor postegar que
estresarme.



No tengo
control sobre
mi vida.





UN LIMÓN, MEDIO LIMÓN

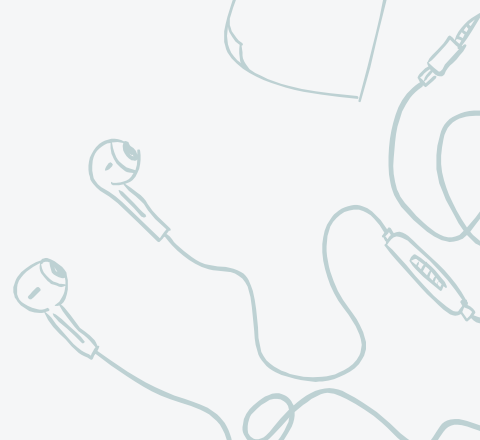
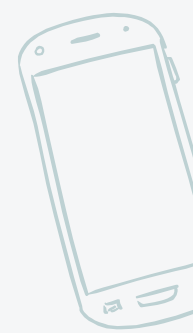

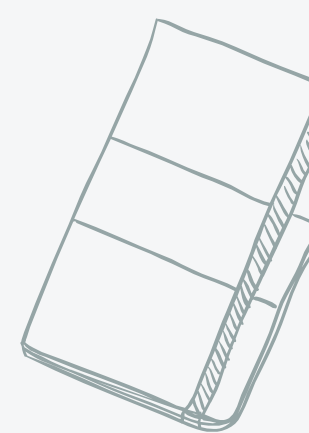
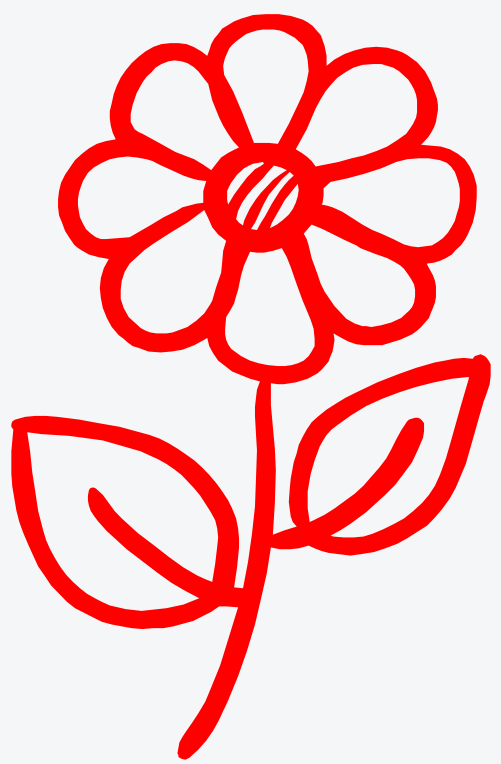

RESPIRA



¿QUÉ RECOMIENDAN
LOS EXPERTOS
PARA MANEJAR EL ESTRÉS?





DEL DICHO AL HECHO...

CONOCE LAS SEÑALES



BUSCA EL EQUILIBRIO



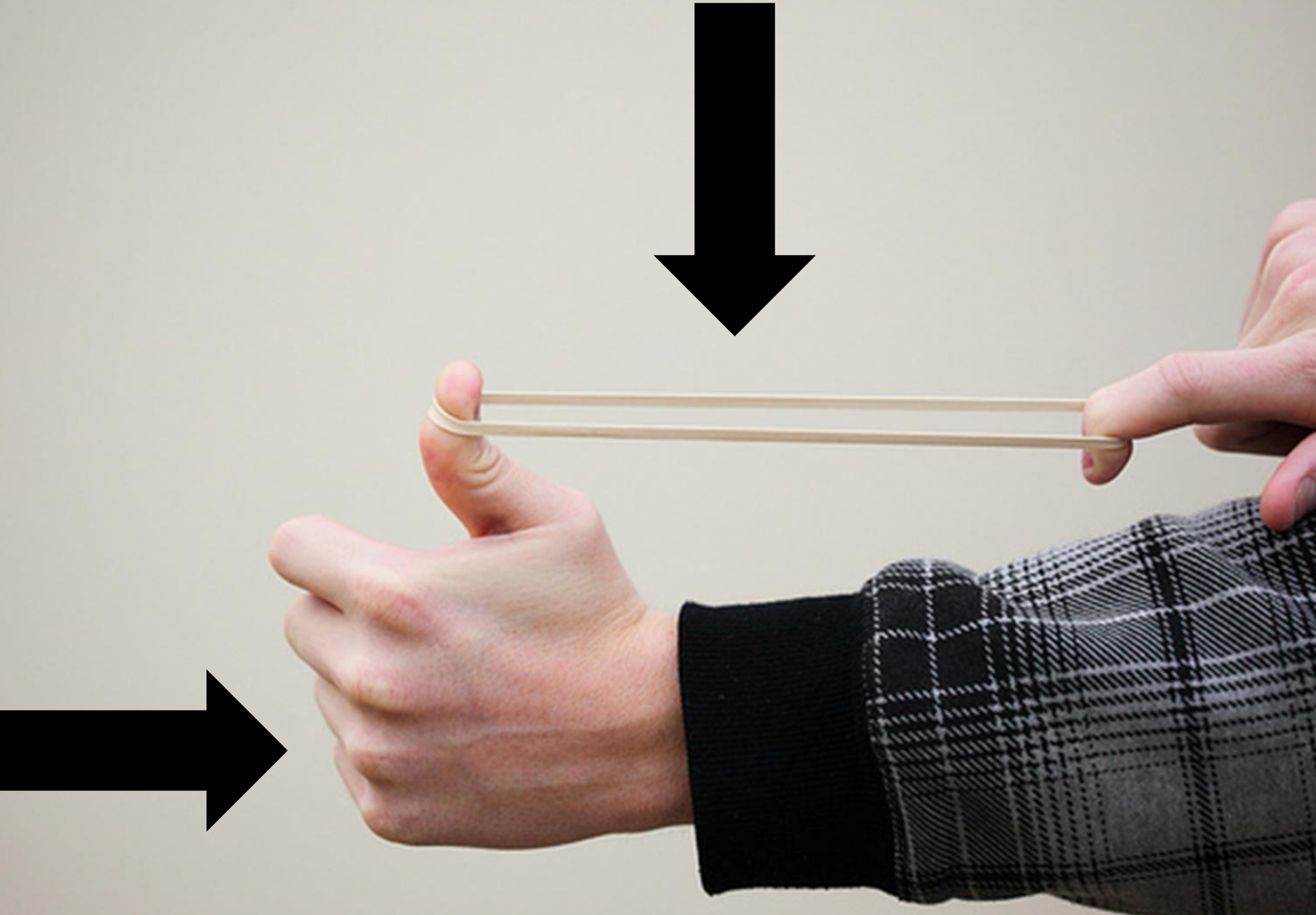



¿ES REALMENTE
PELIGROSO?

¿REALMENTE
NO PUEDO?



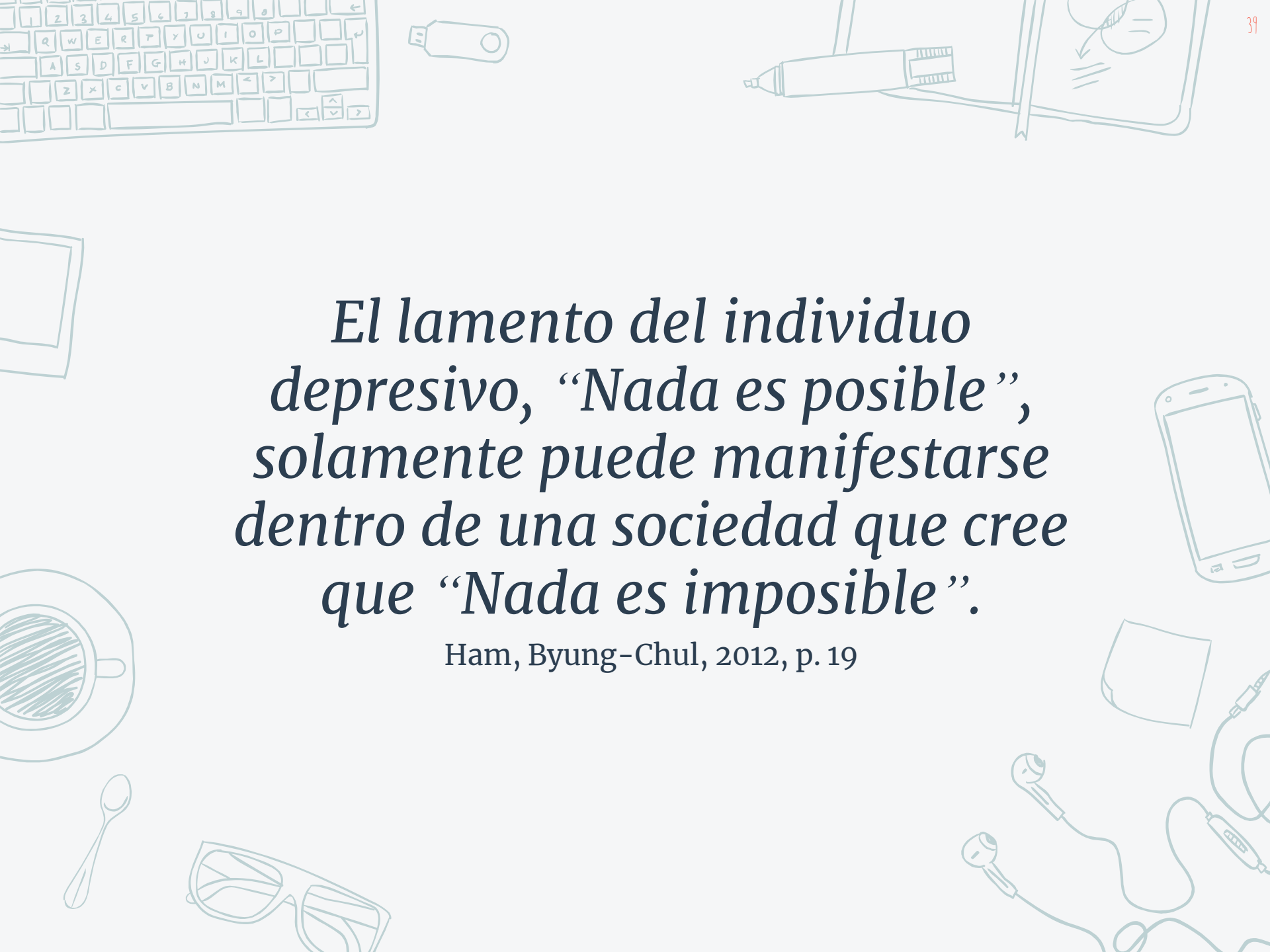

*El lamento del individuo
depresivo, “Nada es posible”,
solamente puede manifestarse
dentro de una sociedad que cree
que “Nada es imposible”.*

Ham, Byung-Chul, 2012, p. 19



AMOR
SE ESCRIBE CON
“ [”

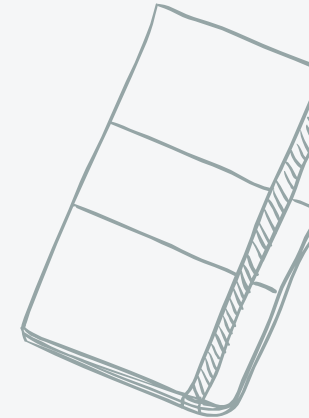



COMPASIÓN

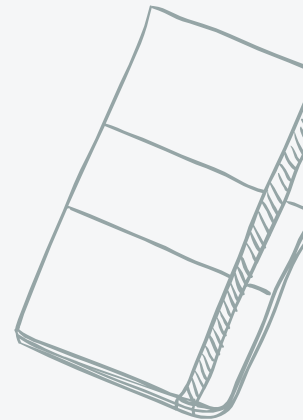
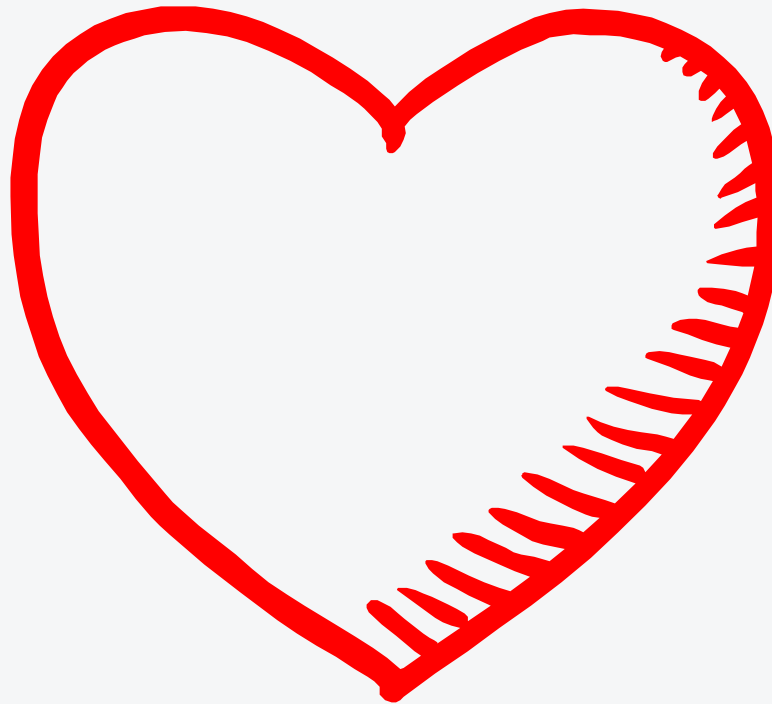

COLABORACIÓN



“VOY A REÍR,
VOY A BAILAR,
VIVIR MI VIDA.
LA, LA, LA.”

MARC ANTHONY





TIEMPO PARA TI

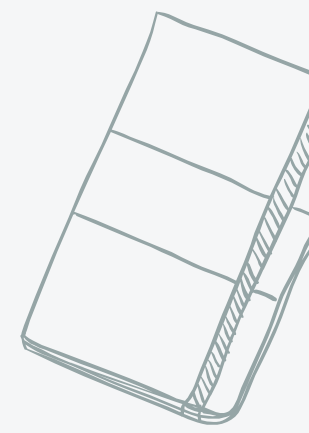



DATE EL PERMISO DE SER FELIZ

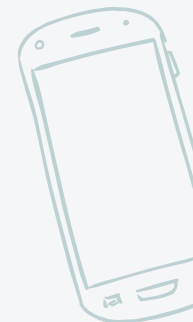

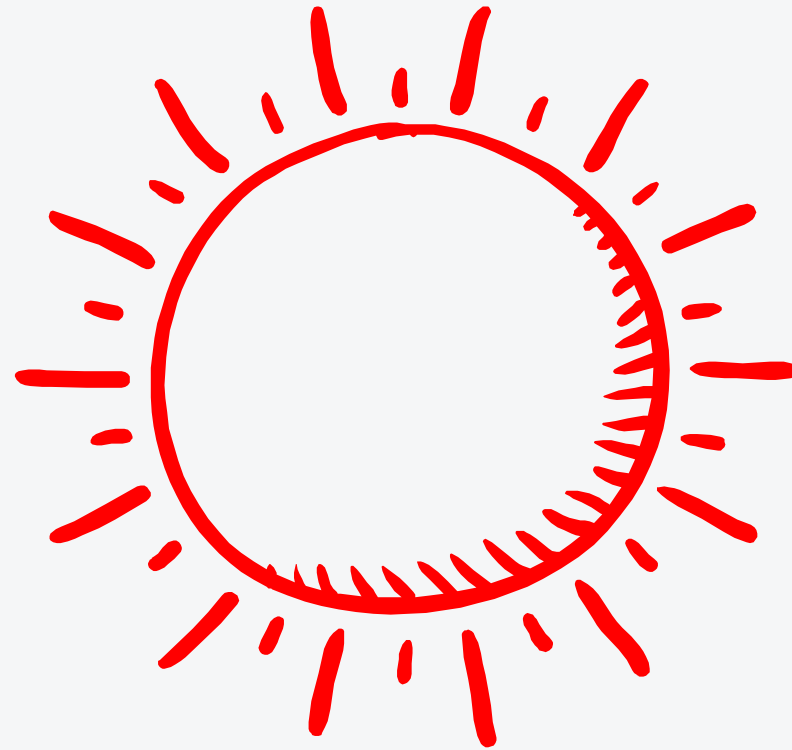

UN FUEGO QUE ARDE, ILUMINA,
MAS NO DEVORA

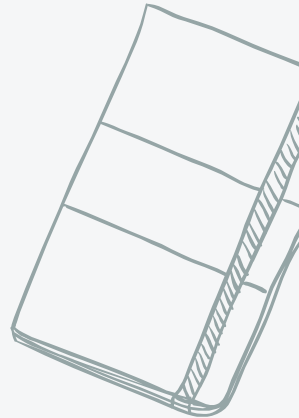

¿QUÉ LE RECOMENDARÍAS A
QUIENES INICIAN ESTA CARRERA?





ESCRIBAMOS UNA
NUEVA HISTORIA



INNOVARTE

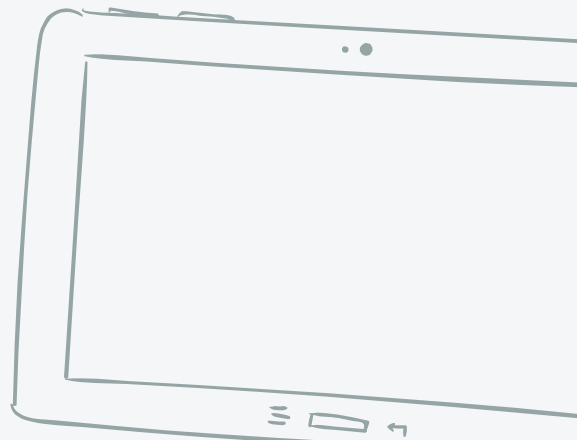
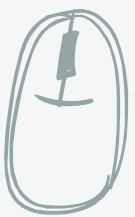
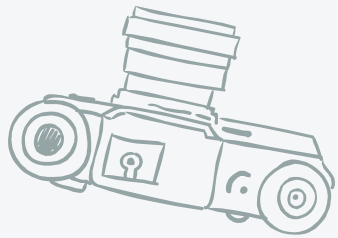



AHORA SÉ...
SOY CAPAZ DE...
COMPRENDO...

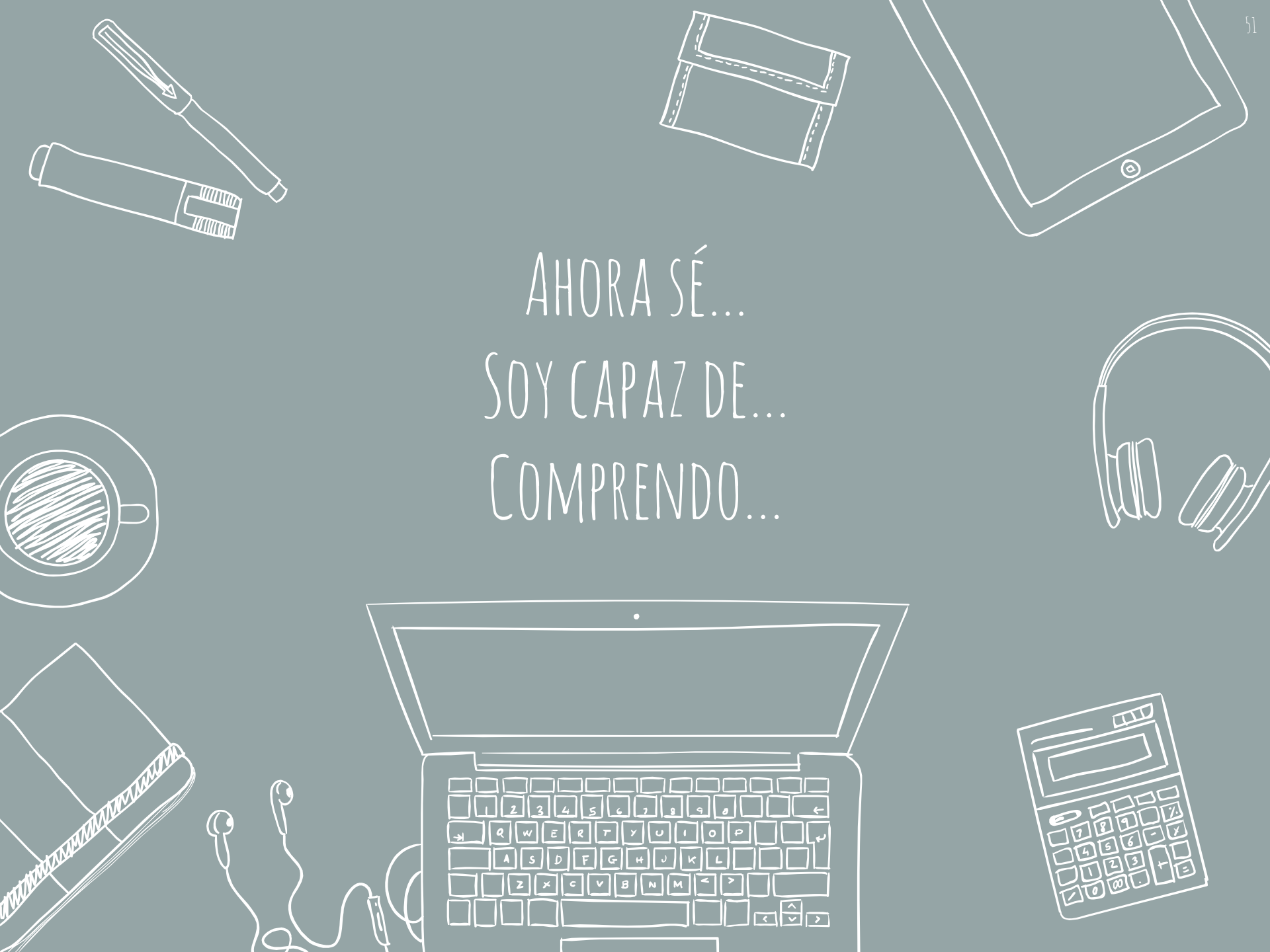

TERMÓMETRO PERSONAL

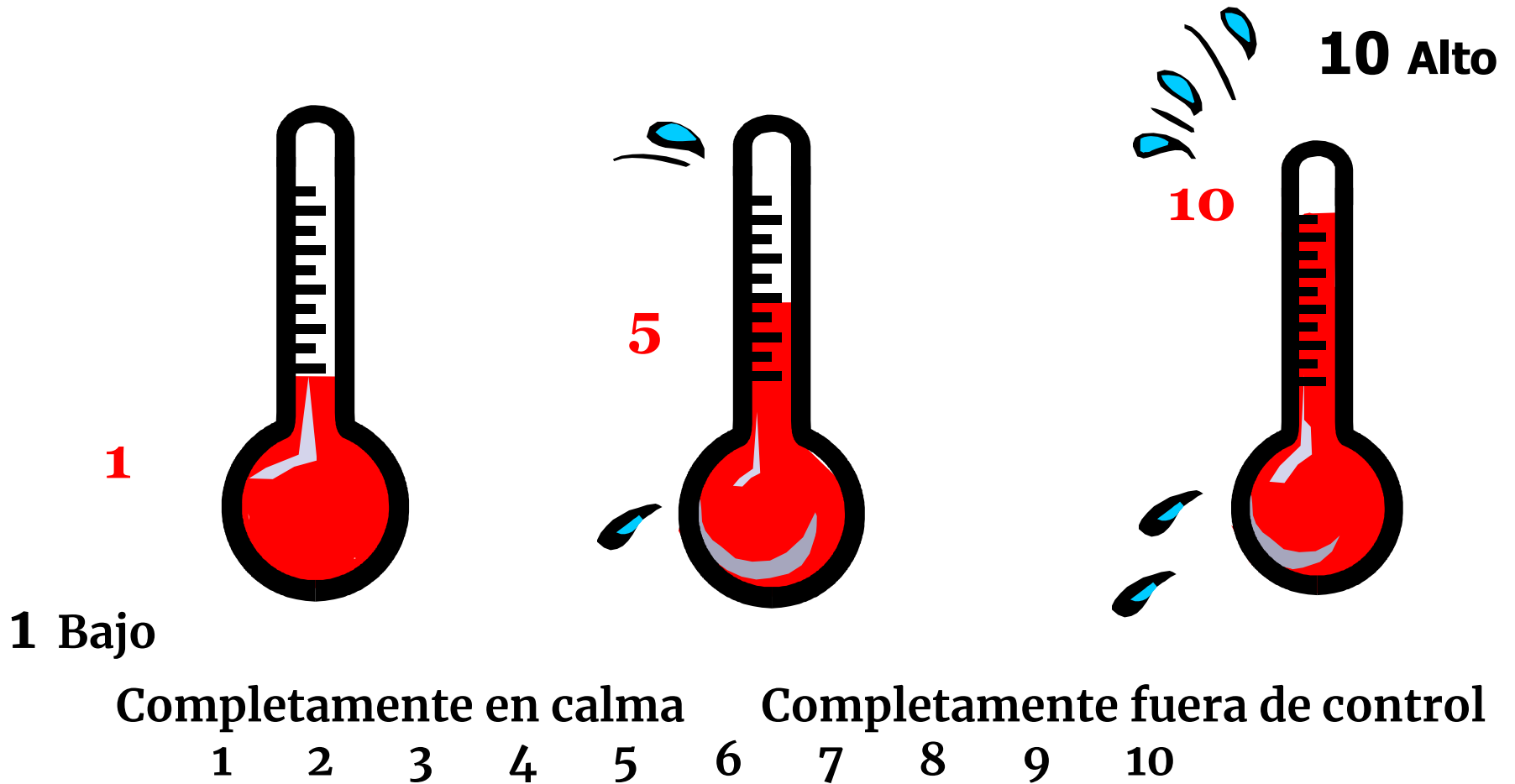



GRACIAS

Miguelina Justo
miguelinajusto@gmail.com



BIBLIOGRAFÍA

Aguilar, N., Blajeroff, N., Anghileri, M., Dabas, D., Acosta, S., Beitía, W.,... & Blajeroff, J. (2016). El burnout docente: Aportes para su superación. En Durand, J., Corengia, J., Daura, F. & Urrutia, S. (Ed), (pp. 342-369). Aprender a enseñar: el desafío de la formación docente inicial y continua: Actas de las VII Jornadas Académicas de la Escuela de Educación de la Universidad Austral. Argentina: teseopress.com. Recuperado de <https://www.teseopress.com/formaciondocente/chapter/221/>

Han, B. (2012). La sociedad del cansancio. Herder: Barcelona, España. Recuperado de <http://raulkoffman.com/wp-content/uploads/2012/07/Byung-Chul-Han-LA-SOCIEDAD-DEL-CANSANCIO.pdf>

Freudenberger HJ. Speaking from Experience. Training & Development Journal. 1977; 31(7):26. <http://search.ebscohost.com/login.aspx?direct=true&AuthType=cookie,url,ip,uid&db=bth&AN=7445417&lang=es&site=eds-live>.

Lazarus, R. S., & Folkman, S. (1984). Stress, Appraisal, and Coping. New York: Springer Publishing Company. Recuperado de: <http://search.ebscohost.com/login.aspx?direct=true&AuthType=cookie,url,ip,uid&db=edsebk&AN=246291&lang=es&site=eds-liv>

Selye, H. (1973). The evolution of the stress concept. American Scientist, 61(6), 692-699.

Wong, V. W., Ruble, L. A., Yu, Y., & McGrew, J. H. (2017). Too Stressed to Teach? Teaching Quality, Student Engagement, and IEP Outcomes. Exceptional Children, 83(4), 412-427. <https://doi.org/10.1177/0014402917690729>